

NXC SERIES RIVET SQUEEZERS

OPERATION MANUAL

TABLE OF CONTENTS

1.0 Overview	2.0 Specifications
3.0 Safety Warnings	4.0 Assembly
5.0 Operation	6.0 Maintenance
7.0 Filling and Bleeding the System	8.0 Contact Information
9.0 Parts Lists	

1.0 Overview

Numatx NXC Series c-squeezers are hydraulically operated hand-held tools, designed to squeeze a variety of rivets. These units are hydropneumatic operated (also known as pneudraulic), in conjunction with Numatx pressure intensifiers, such as the NXI-40. The aforementioned intensifier has been sized specifically to work with the NXC Series c-squeezers, during commercial riveting operations. The fully hydraulic c-squeezers offers the advantages of decreased weight, smaller size, and greater control when compared to traditional pneumatic only squeezers. This reduces operator fatigue, allows for use in more confined areas, and improves control of the squeezing action (feathering operation). The units are built from high quality aircraft grade materials, with parts made on CNC machining centers and features held to close tolerances, for years of dependable operation.

Before using the Numatx NXC Series C-Squeezers, please fully read and understand this operation manual.

2.0 Specifications

AIR PRESSURE, MIN	30-PSIG
AIR PRESSURE, MAX	90-PSIG
DIMENSIONS	FIGURE 1
WEIGHT (NO YOKE), NXC-4	1.25 Lbm (.56 Kg)
WEIGHT (NO YOKE), NXC-6	1.72 Lbm (.78 Kg)
WEIGHT (NO YOKE), NXC-9	2.00 Lbm (.91 Kg)
FLUID DISP REQUIRED, NXC-4	.55 in ³ (9.0 cc)
FLUID DISP REQUIRED, NXC-6	.97 in ³ (15.9 cc)
FLUID DISP REQUIRED, NXC-9	1.32 in ³ (21.6 cc)
HYDRAULIC PRESSURE, NORMAL	3,500 psi (24.1 MPa)
HYDRAULIC PRESSURE, MAX	4,500 psi (31.0 MPa)
FORCE AT NORMAL HYD PRESSURE, NXC-4	3,600 Lbf (16.0 KN)
FORCE AT NORMAL HYD PRESSURE, NXC-6	6,445 Lbf (28.6 KN)
FORCE AT NORMAL HYD PRESSURE, NXC-9	8,790 Lbf (39.1 KN)
COMPRESSION PIN TRAVEL	.550" (14 mm)

3.0 Safety Warnings

- 3.1 **Never operate the system below 30-psig or above 90-psig air pressure.**
- 3.2 NEVER operate the c-squeezers above 4,500 psi (31.0 Kg/cm²) hydraulic pressure. Operating above this specified pressure can lead to failure of the hydraulic hose, hydraulic seals, and fittings.
- 3.3 NEVER disconnect the hydraulic line while the line is pressurized.
- 3.4 Use Dexron III or equivalent fluid for the c-squeezer actuation fluid. Other fluids such as MIL-7808 turbine oil may be suitable, providing the Buna-N (Nitrile) seals are compatible with the alternate fluid.
- 3.5 Properly bleed the c-squeezer per Section 7 of this manual. The entire system must be bled properly for optimum performance.
- 3.6 Use proper eye protection when operating this unit.
- 3.7 Do not use substitute components for repair of any portion of the unit.
- 3.8 The system should be properly maintained and examined at regular intervals for damage.
- 3.9 Avoid excessive contact with the hydraulic fluid, to minimize skin irritation. Refer to Section 6 for Dexron III safety data.

4.0 Assembly

- 4.1 Refer to Figure 3 for light duty yokes, suitable for the NXC-4.
- 4.2 Refer to Figure 4 for heavy duty yokes, suitable for the NXC-6 and NXC-9 c-squeezers.
- 4.3 Refer to Figure 5 for installation views of the c-yoke, compression pins and bolts.
- 4.4 Refer to Figure 6 for components included with the system, and Figure 7 for the system setup.
- 4.5 Refer to Figure 8 for setup of the foot valve.
- 4.6 Install an AN816-4D fluid fitting or male QD (PN 6705) into the fluid inlet port of the hand-held c-squeezer. Use Teflon tape on the pipe threads, to ensure there are no hydraulic leaks.
- 4.7 Install an AN816-4D fluid fitting into the end of the pressure intensifier. Use Teflon tape on the pipe threads, to ensure there are no hydraulic leaks.
- 4.8 For the NXC-4, there are two compression pins supplied with the squeezer. Attach the compression pin to the piston tip using the supplied 3-48 cap screw. **DO NOT** tighten this screw, bring the compression pin to close engagement with the tip of the piston only. The screw is left slightly loose in order to allow for radial float of the compression pin, for any tolerance mismatch of the installed c-yoke. Apply thread lock (Loctite) sparingly to the threads if there is a concern of the screw loosening. Lubricate the compression pin shank using a suitable lithium-based grease.
- 4.9 For the NXC-6 and NXC-9, install the spring, spring retainer, and retention ring onto the compression pin, and the pin into the intended c-yoke. Lubricate the pin shank using a suitable lithium-based grease. Note the order of the installed components.
- 4.10 Refer to Figure 10 for variations of compression pins that can be used with the c-yokes. The default compression pin used with Numatx NXY HD yokes is a -15. Some pre-planning on compression pin length may be necessary, factoring in compression pin travel (.550"), c-yoke deflection, and necessary retraction distance for part clearance.
- 4.11 Install an appropriate CP-214 compatible c-yoke into the squeezer yoke mount, using the supplied quick release shear pins for the NXC-4, or the supplied Grade 9 mounting bolts for the NXC-6 and NXC-9. Do not use alternate mounting pins or bolts, as these pins/bolts are under considerable shear forces.
- 4.12 All CP-214 compatible c-yokes will have a mounting width of .560" (the width of the c-yoke that is inserted into the c-squeezer mount block). Some Heavy Duty (HD) yokes, typically 1.0" thick, may require a slight modification to fit the Numatx c-squeezers. Refer to figure 5. Numatx c-yokes are a direct fit into the yoke mount.
- 4.13 Torque the shear bolts to 160 Lb-In (18.0 N-M).
- 4.14 Mount an appropriate rivet die in the tip of the compression pin and c-yoke. The c-squeezers are set up to receive rivet dies with .187 diameter (3/16") shanks.

- 4.15 Connect the c-squeezer directly to the hydraulic hose, using an AN816-4D fitting. Alternately, attach a female Quick Disconnect (QD) (PN 6706) to the hydraulic hose end. QDs are used when connecting different squeezer heads to the one pressure intensifier.
- 4.16 Install the ¼" air lines between the foot valve and intensifier, using the supplied one-touch air fittings. Use Teflon tape on the threads of the air fittings. Note that the default position of the foot valve (pedal un-depressed) should be flowing air to the air fitting located on the top of the intensifier. When the foot valve pedal is depressed, air should be flowing to the air fitting at the bottom of the intensifier.
- 4.17 Bleed the riveter system per Section 7.

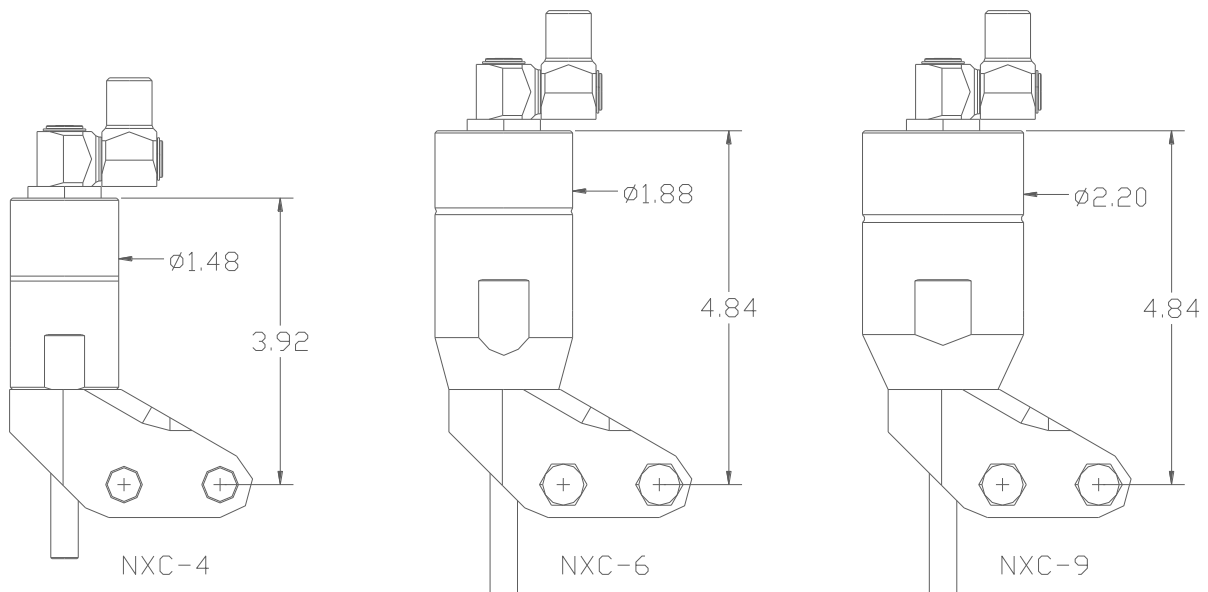

FIGURE 1 – GENERAL DIMENSIONS (NO YOKE INSTALLED)

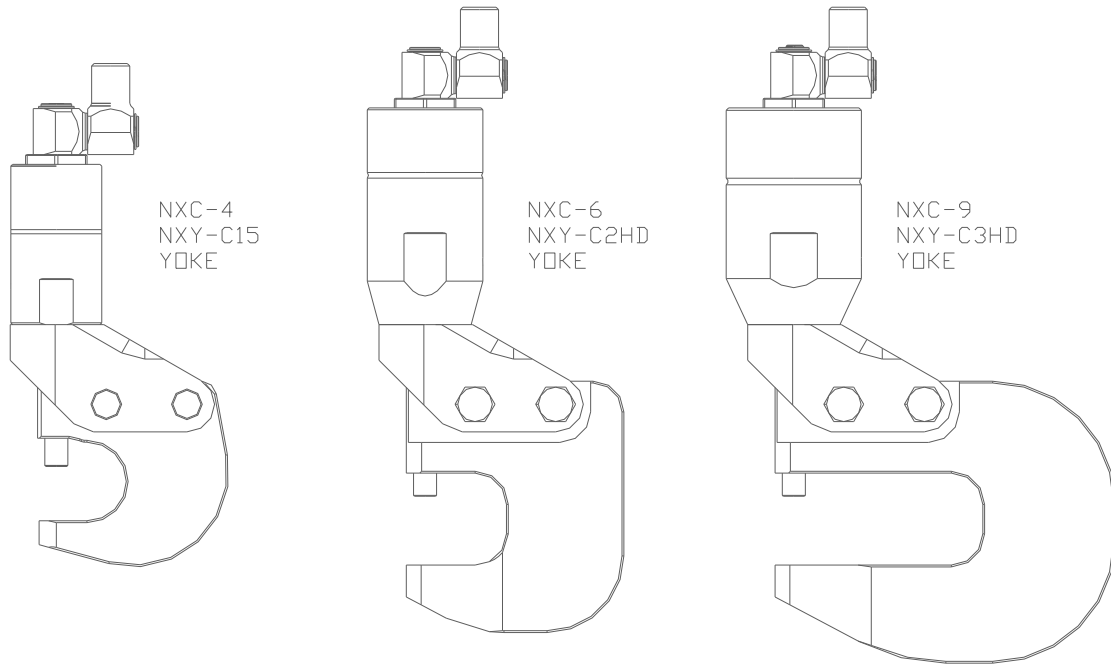

FIGURE 2 – TYPICAL C-YOKES USED

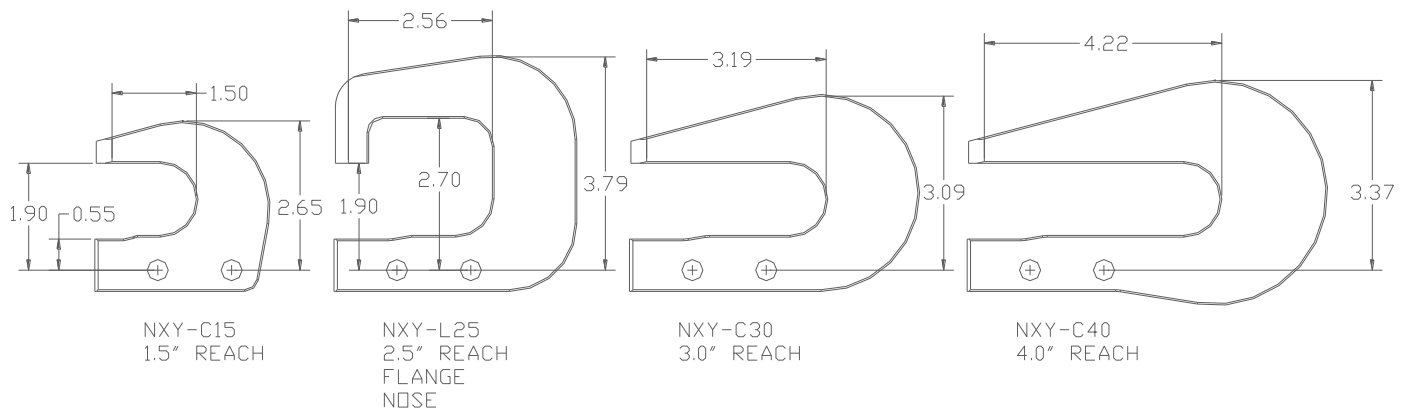

FIGURE 3 – LIGHT-DUTY C-YOKES

(FOR NXC-4 AND NXC-6 - .560" THICKNESS)

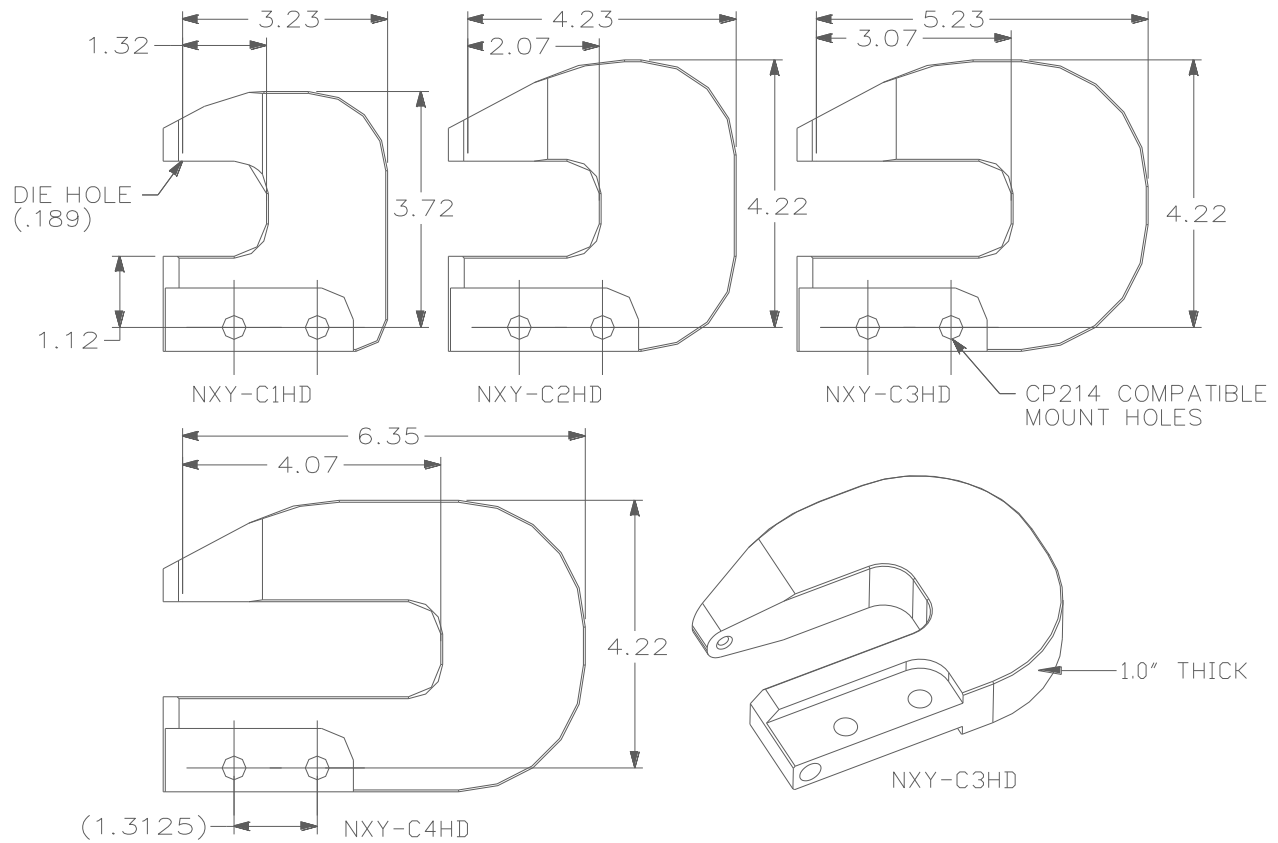

FIGURE 4 – HEAVY-DUTY C-YOKES

(FOR NXC-6 AND NXC-9 – 1.00" THICKNESS)

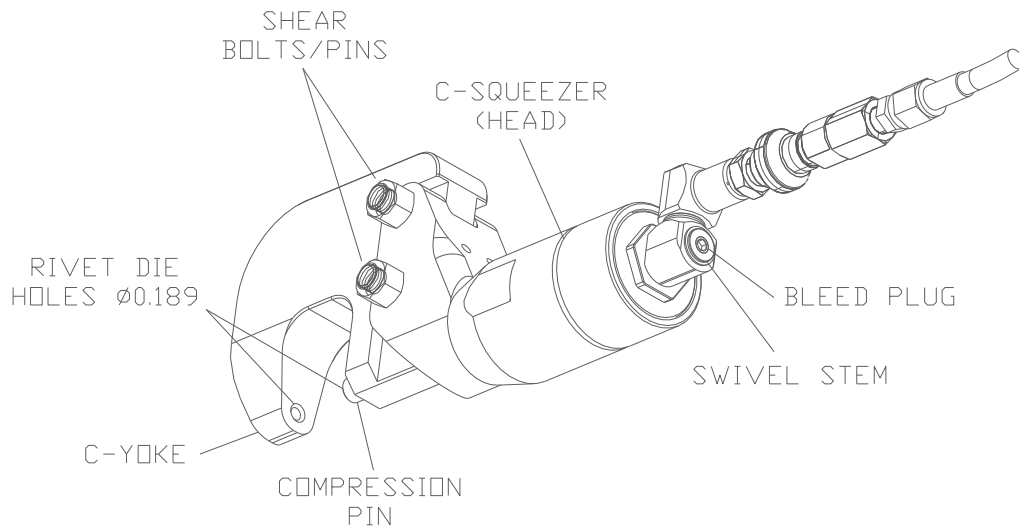

FIGURE 5 – C-SQUEEZER COMPONENTS

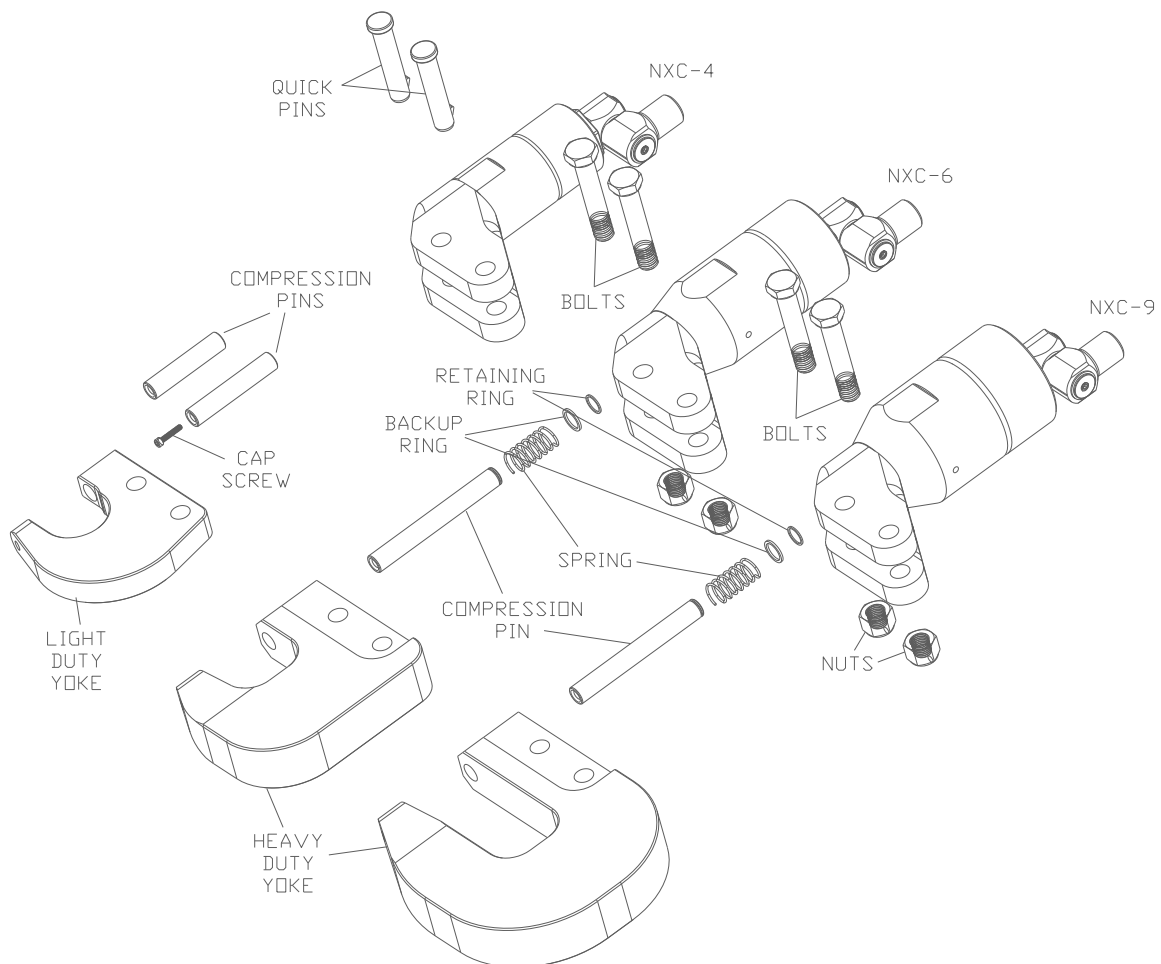

FIGURE 6 – YOKE / COMPRESSION PIN / BOLT INSTALLATION

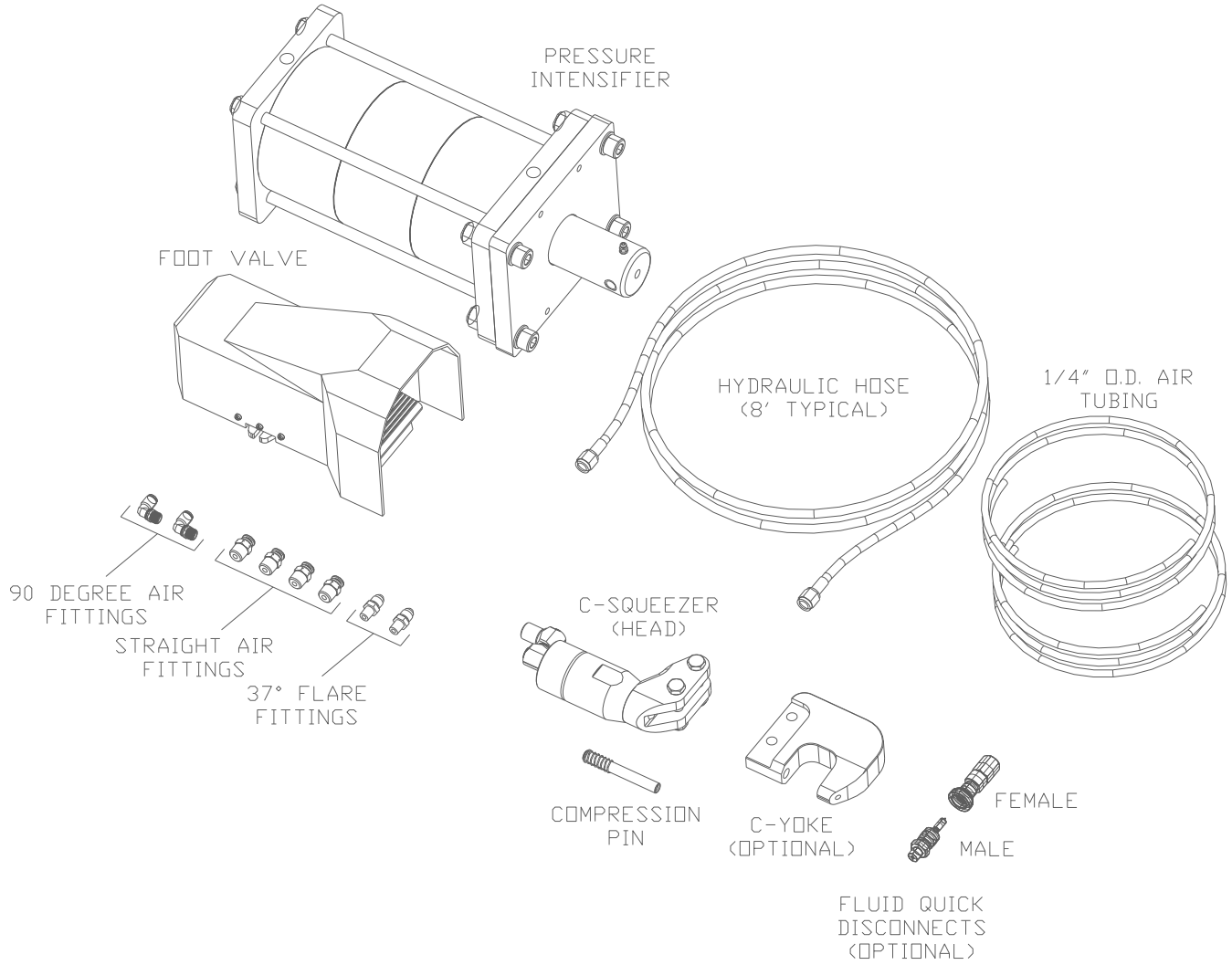

FIGURE 7 – SYSTEM COMPONENTS

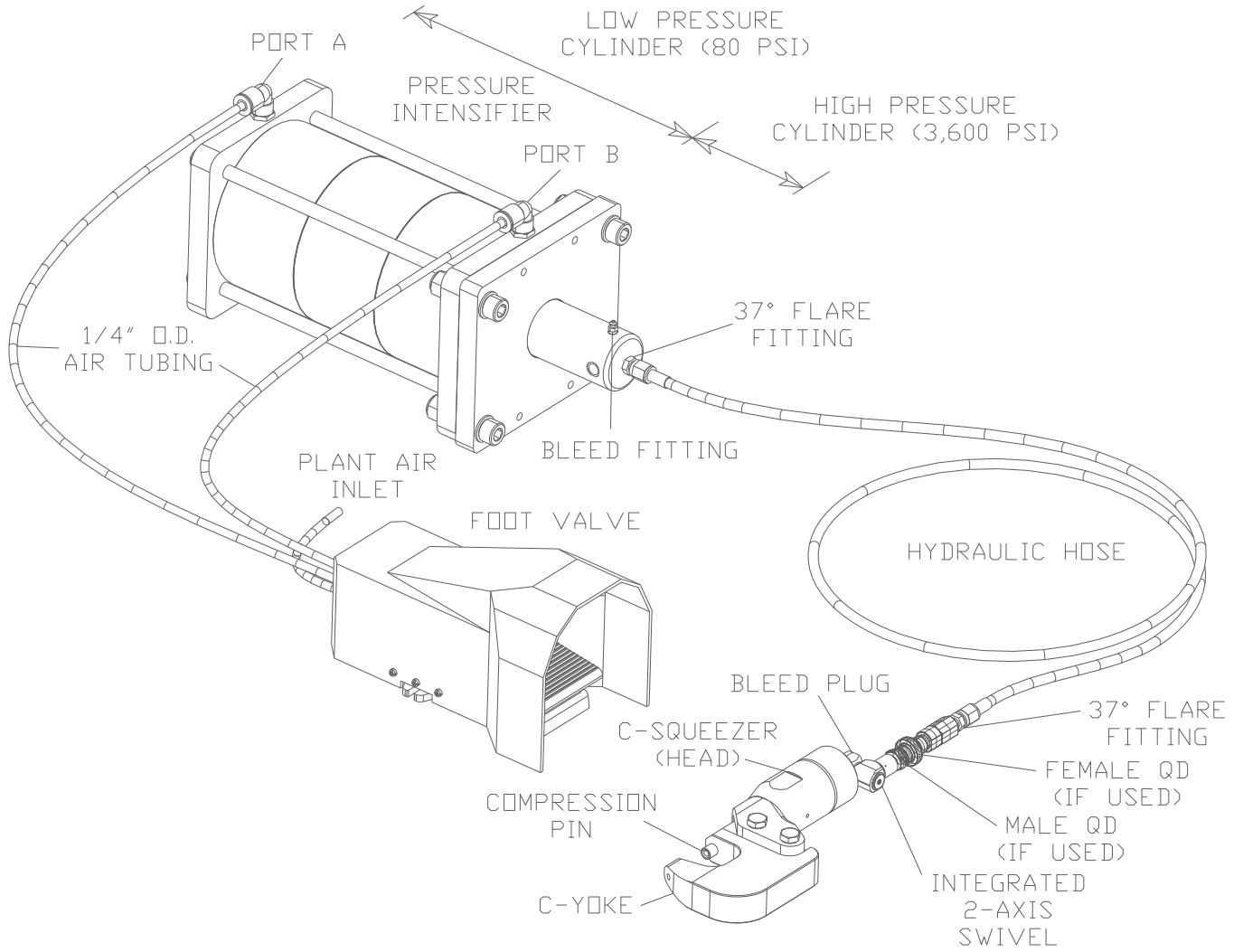

FIGURE 8 – SYSTEM SETUP

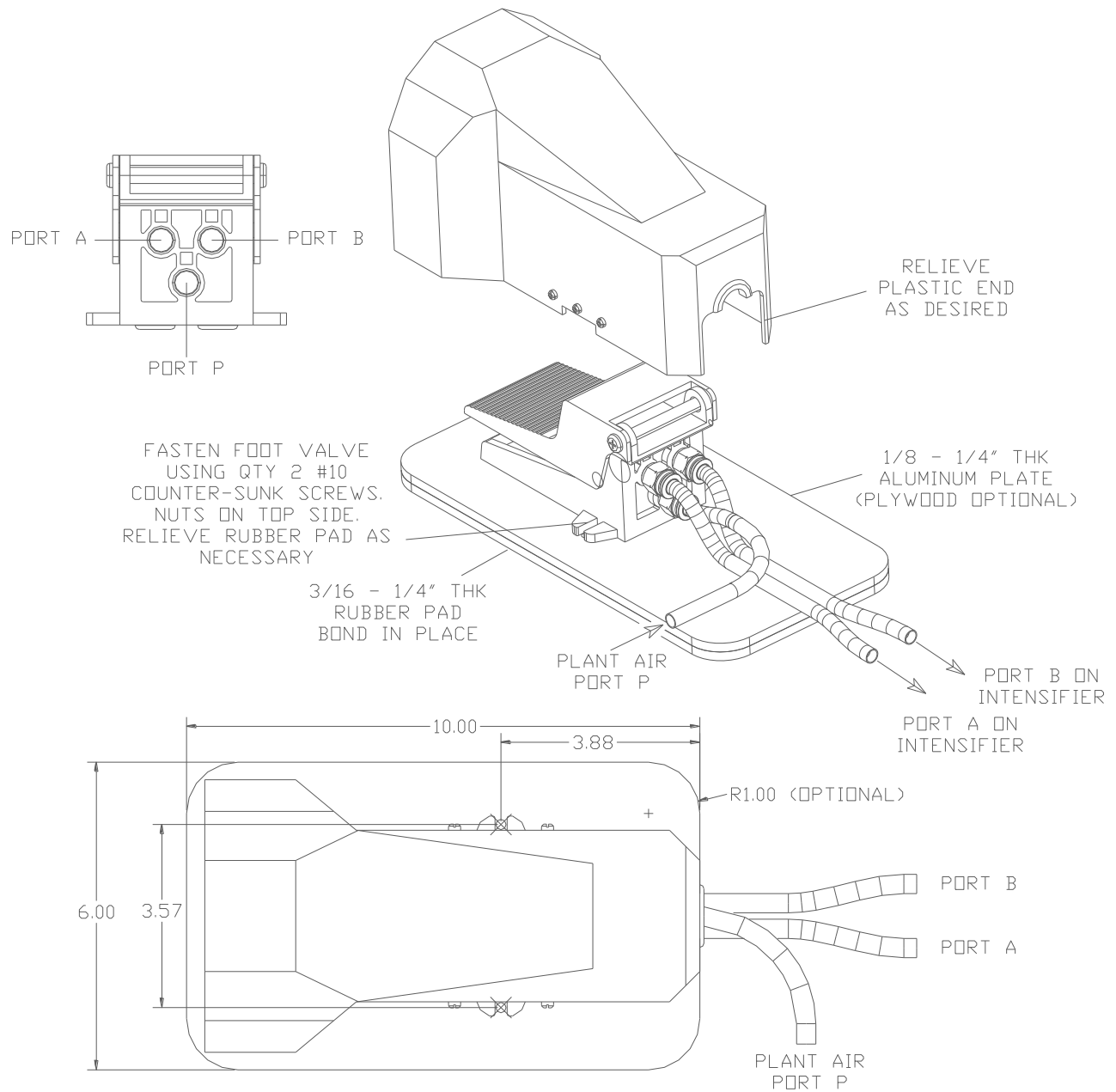
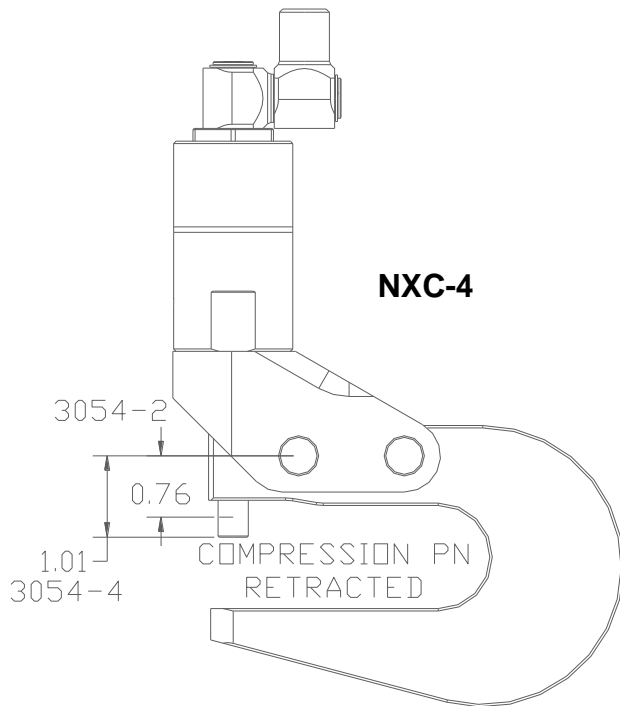

FIGURE 9 – FOOT VALVE SETUP



COMPRESSION PIN LENGTHS

DASH	L	H	DASH	L	H
-1	2.175	.625	-16	3.113	1.563
-2	2.238	.688	-17	3.175	1.625
-3	2.300	.750	-18	3.238	1.688
-4	2.363	.813	-19	3.300	1.750
-5	2.425	.875	-20	3.363	1.813
-6	2.488	.938	-21	3.425	1.875
-7	2.550	1.000	-22	3.488	1.938
-8	2.613	1.063	-23	3.550	2.000
-9	2.675	1.125	-24	3.613	2.063
-10	2.738	1.188	-25	3.675	2.125
-11	2.800	1.250	-26	3.738	2.188
-12	2.863	1.313	-27	3.800	2.250
-13	2.925	1.375	-28	3.863	2.313
-14	2.988	1.438	-29	3.925	2.375
-15	3.050	1.500	-30	3.988	2.438

-15 SUPPLIED
H = 1.500

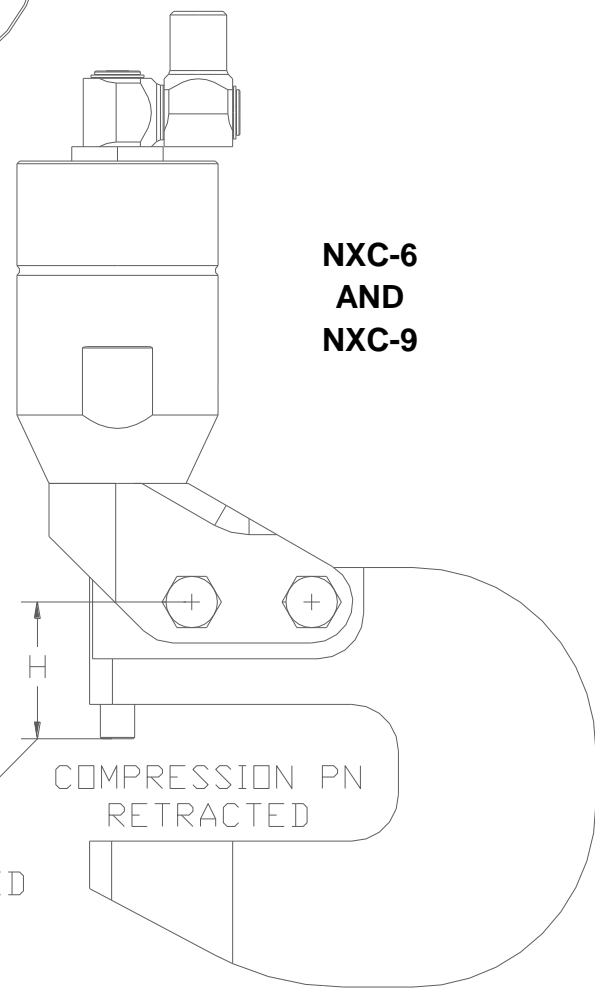

FIGURE 10 – COMPRESSION PIN LENGTHS

5.0 Operation

Operation of the Numatx NXC series c-squeezers requires understanding of one basic fact: Numatx c-squeezers make CONSTANT FORCE over the entire stroke range (.550" / 14mm of stroke). This is due to the fact that the Numatx squeezers are fully hydraulic for the hand-held portion.

Traditional pneumatic squeezers develop peak squeezing force at approximately the final 1/8" of compression pin travel. Pneumatic squeezers are ALWAYS adjusted so that the rivet set has almost run out of travel as the rivet is about to be compressed. This typically requires spending extra time adjusting the length of the rivet set, to achieve the peak force available.

When a pneumatic squeezer is working well for one rivet length, it may require additional adjustment to squeeze a different length rivet. As little as .040" (1mm) may make the difference whether the pneumatic squeezer can squeeze the rivet or not.

Since the Numatx c-squeezers have constant force, the force is the same for the first .001 of travel as it is for the final .550" of travel. Therefore, only gross adjustment of the compression pin is necessary, to allow for installation of rivet dies and varying lengths of rivets.

Adjust the air pressure supplied to the pressure intensifier, within the allowable operating range of the intensifier. Air pressure and hydraulic pressure will be directly proportional; thus, the force of the squeezer is directly proportional to air pressure. Calculated forces for all c-squeezers are shown in Table 1 below. Table 2 lists the forces for selected rivet materials and diameters. Once the desired air pressure is achieved for a particular rivet material and rivet diameter, no further adjustment will be necessary to squeeze similar rivets of different lengths, providing the compression pin does not run out of travel.

- 5.1 Install rivet dies in the tip of the compression pin and c-yoke, appropriate to the rivet being squeezed. The die and yoke combination need to allow for removal of the tool, after squeezing the rivet, for example clearance past a structural flange. The dies can be installed in either orientation of the tool, the motion of the compression pin is relative.
- 5.2 To squeeze a rivet, depress the foot pedal (or actuate a control valve) connected to the intensifier. The pressure intensifier will displace hydraulic fluid along the length of the hydraulic hose, forcing the piston in the squeezer to move.
- 5.3 Advance of the compression pin can be controlled finely by "feathering" the action. This is accomplished by only slightly depressing the foot valve pedal.
- 5.4 To retract the squeezer compression pin, release the foot valve (or actuate a control valve). The piston of the intensifier will return to a retracted state, allowing the fluid in the squeezer to return to the intensifier.

TABLE 1 – C-SQUEEZER FORCES

CALCULATED FORCES FOR NXC SERIES C-SQUEEZERS
 USING NXI-40 INTENSIFIER AT PRESSURES GIVEN BELOW
 80 PSI AIR PRESSURE PRODUCES NORMAL HYD PRESSURE OF 3,680 PSI

DESCRIPTION	AIR PRESSURE (PSI)					
	40	50	60	70	80	90
NXC-4 4K SQUEEZER FORCE (Lbf)	1,800	2,250	2,700	3,150	3,600	4,050
NXC-6 6K SQUEEZER FORCE (Lbf)	3,223	4,028	4,834	5,639	6,445	7,251
NXC-9 9K SQUEEZER FORCE (Lbf)	4,397	5,496	6,595	7,694	8,793	9,893

BODY DIAMETER	MATERIAL	FORCE Lbf	FORCE KN	RIVET STYLE
3/32" (2.4 MM)	2017-T4	2,000	9	"D" RIVET
	2024-T4	1,600	7	"DD" RIVET
	2117-T4	1,500	7	"AD" RIVET
	A-286	7,500	33	
	MONEL	2,500	11	
1/8" (3.2 MM)	TITANIUM	6,000	27	
	2017-T4	2,400	11	"D" RIVET
	2024-T4	2,000	9	"DD" RIVET
	2117-T4	1,900	8	"AD" RIVET
	A-286	9,600	43	
5/32" (4.0 MM)	MONEL	4,400	20	
	TITANIUM	9,200	41	
	2017-T4	3,500	16	"D" RIVET
	2024-T4	3,500	16	"DD" RIVET
	2117-T4	2,900	13	"AD" RIVET
3/16" (4.8 MM)	A-286	14,200	63	
	MONEL	6,000	27	
	TITANIUM	14,500	64	
	2017-T4	4,800	21	"D" RIVET
	2024-T4	4,800	21	"DD" RIVET
1/4" (6.4 MM)	2117-T4	4,000	18	"AD" RIVET
	A-286	19,700	88	
	MONEL	10,250	46	
	TITANIUM	19,800	88	
	2017-T4	9,000	40	"D" RIVET
	2024-T4	10,600	47	"DD" RIVET
	2117-T4	8,500	38	"AD" RIVET
	A-286	31,600	141	
	MONEL	17,500	78	
	TITANIUM	35,200	157	

TABLE 2 – RIVET SQUEEZING FORCE FOR SELECT MATERIALS AND DIAMETERS

6.0 Maintenance

The NUMATX NXC series c-squeezers have been manufactured to give maximum service with minimum care. In order that this may be accomplished, the following recommendations should be followed.

- 6.1 The squeezer system should be full of oil and properly bled per Section 7.
- 6.2 Use only Dexron III or fluid compatible with Buna-N (Nitrile) seals. See Dexron III safety Data below.
- 6.3 Keep the unit clean and free of excessive moisture, to minimize wear on moving parts. Prevent dirt from entering the air inlet QD of the intensifier.
- 6.4 It is recommended to use dry filtered air as a pressure source to the intensifier, which will extend the seal life of the intensifier piston.
- 6.5 The system should be routinely inspected for oil leaks. Check the bleed fitting of the intensifier and bleed plug of the c-squeezer to ensure they are tight. DO NOT OVERTIGHTEN.
- 6.6 The bleed plug in the c-squeezer head may be removed to examine the fluid level. Re-install using Teflon tape and tighten.
- 6.7 Avoid dropping any portion of the unit, as this may cause damage to close tolerance parts.
- 6.8 Section 9 shows an exploded parts list for all tools.

DEXRON III OIL SAFETY DATA

FIRST AID

Skin: Wash thoroughly with soap and water as soon as possible. Casual contact requires attention.

Ingestion: Seek Medical attention, immediately. DO NOT INDUCE VOMITING.

Eyes: Flush with copious amounts of water. If irritation develops, consult a physician.

Inhalation: No significant adverse health effects are expected to occur on short term exposure. Remove from contaminated area. Apply artificial respiration if needed. If unconscious, consult a physician.

FIRE

Suitable extinguishing media: CO₂, dry powder, foam or water fog. DO NOT use water jets.

ENVIRONMENT

Waste Disposal: In accordance with local, state and federal regulations.

Spillage: Prevent entry into drains, sewers and water courses. Soak up with inert material. Store waste fluid in an appropriate container for disposal.

Handling: Eye protection required. Protective gloves recommended. Chemically resistant boots and apron recommended. Use in a well-ventilated area.

Combustibility: Slightly combustible when heated above flash point. Will release flammable vapor which can burn in open or be explosive in confined spaces if exposed to a source of ignition.

PROPERTIES

Specific gravity: 0.863 Weight per gallon: 7.18 lbs. Flash point: >200°C (392°F)

7.0 Filling and Bleeding the System

In order to develop maximum force and full compression pin travel, entrapped air bubbles must be removed from the system. Bleeding the system is similar to bleeding brakes on a car. If a QD is used in the system, and is disconnected routinely, the bleeding frequency will be higher than a system without a QD. Bleeding the unit may take some patience and as much as 1/2 hour of time. It may be necessary to pass the equivalent of several 50-60cc charges of fluid through the unit to fully dispel any trapped air. If the unit does not seem to be performing properly, it is likely not fully bled of all air. Refer to Figure 11.

Numatx offers a Model 3450-1 Power Bleeder, which can make system bleeding easier. Low pressure air (20-30 psig) is used to force hydraulic fluid into the system. The Power Bleeder holds a sufficient quantity of fluid for several system charges.

- 7.1 Place the unit so that the intensifier and the hydraulic hose are below the c-squeezer. Try to minimize low points in the hydraulic hose, which could create space for an air pocket. The air lines to the intensifier do not need to be hooked up, providing that the intensifier air cylinder is fully retracted. The bleed port on the c-squeezer should be as close to the relative high point in the system as possible, to preclude the possibility of an air pocket. Remove the c-squeezer bleed plug, and install a 1/8" NPT barb fitting and clear tube into the port, to channel excess fluid to a waste cup.
- 7.2 Slightly open the bleed fitting on the intensifier approximately 1 to 1-1/2 turns. Do not overly open this fitting, or else residual fluid may exit the intensifier due to gravity.
- 7.3 Attach a 1/4" O.D. tubing to the syringe, and fill the syringe with Dexron III fluid.
- 7.4 Make sure all air bubbles are out of the syringe and attached tubing before hooking it up to the bleed fitting of the intensifier. To do this, position the syringe so that the tubing is facing upward, and allow a small quantity of fluid to be dispelled from the syringe, forcing any air bubbles fully out of the syringe and attached tubing.
- 7.5 Inject the fluid into the intensifier bleed fitting. If it is difficult to force the fluid into the unit, SLIGHTLY open the bleed fitting in approximately 1/2 turn increments.
- 7.6 Observe the tubing connected to the c-squeezer, watching for fluid exiting the clear tube. Continue injecting hydraulic fluid until no air bubbles are seen in the fluid exiting the c-squeezer. An unfilled system requires several 50-60cc syringe injections.
- 7.7 Injecting the fluid at a slower rate may lessen cavitation of air bubbles within the c-squeezer hydraulic cylinder. The goal is to remove ALL air bubbles.
- 7.8 When finished injecting fluid, tighten the bleed fitting of the intensifier BEFORE removing the tubing from the bleed fitting. This will prevent additional air from entering the system.
- 7.9 Remove the clear barb fitting and tube at the c-squeezer, and check the fluid level at the port. Fluid may be added to "top off" the unit.
- 7.10 Reinstall the c-squeezer bleed plug and tighten. Use Teflon tape on the pipe threads. DO NOT over-tighten this bleed plug. Do not drive the bleed plug substantially below flush, as shown in Figure 12.
- 7.11 Wipe up any excess fluid present on the intensifier and c-squeezer.

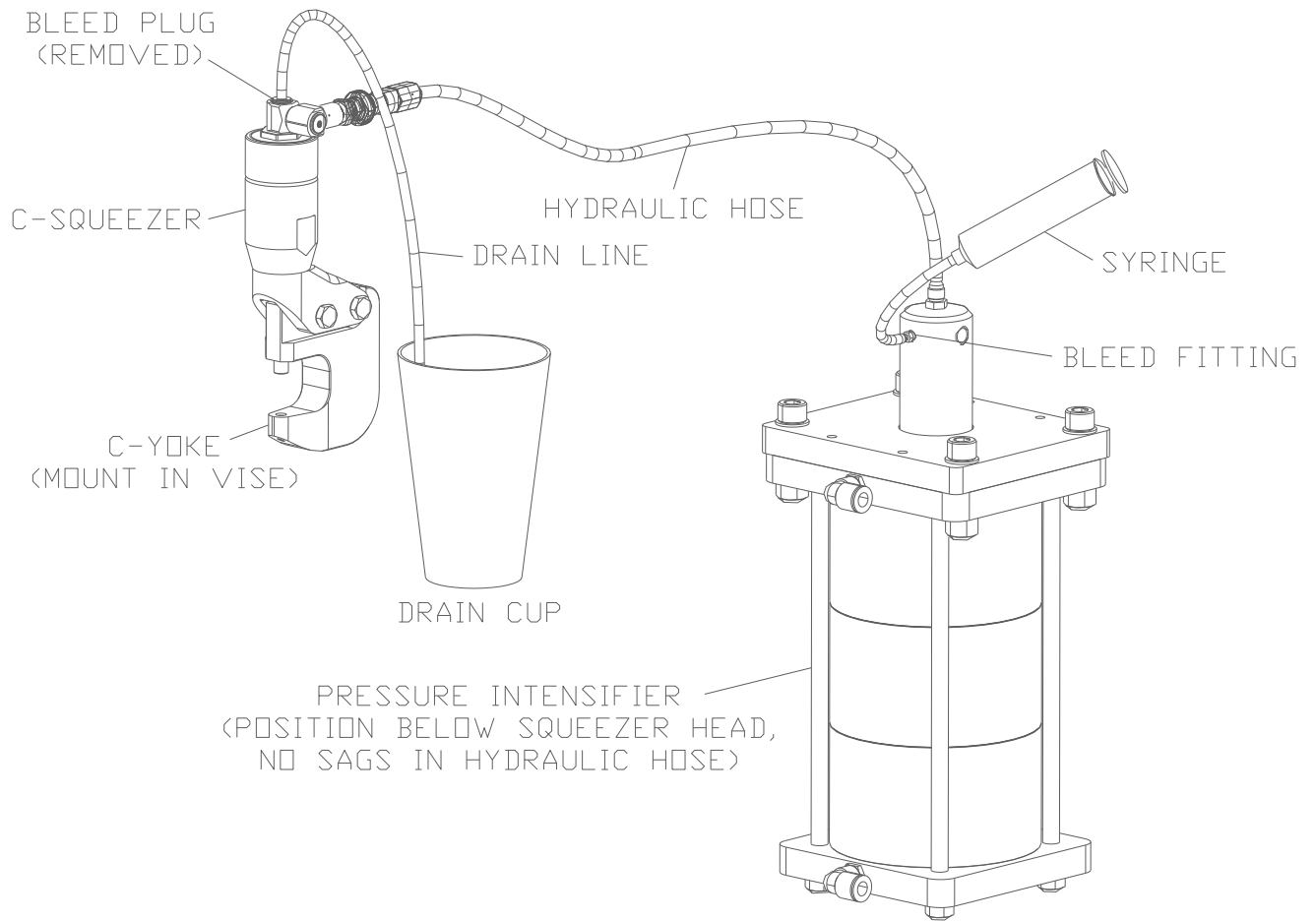

FIGURE 11 – BLEEDING SETUP

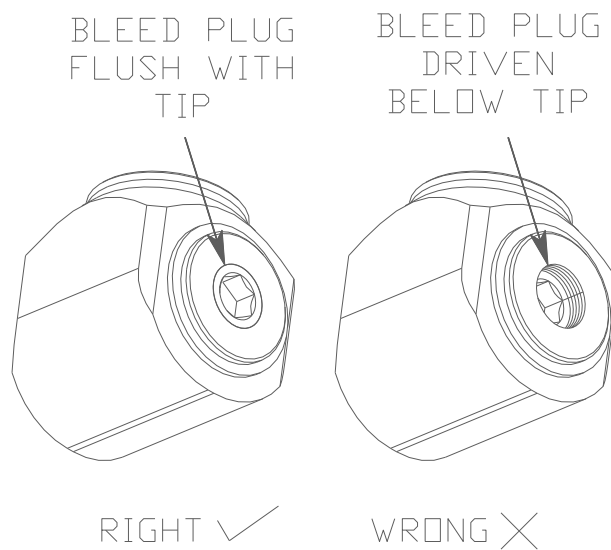

FIGURE 12 – PROPER BLEED PLUG INSTALLATION

8.0 Contact Information

NUMATX welcomes any comments, suggestions or questions regarding this product.



25 Leonberg Road
Cranberry Twp., PA 16066
Phone: 724-776-6800
Fax: 724-776-0227

9.0 Parts Lists (See following pages)

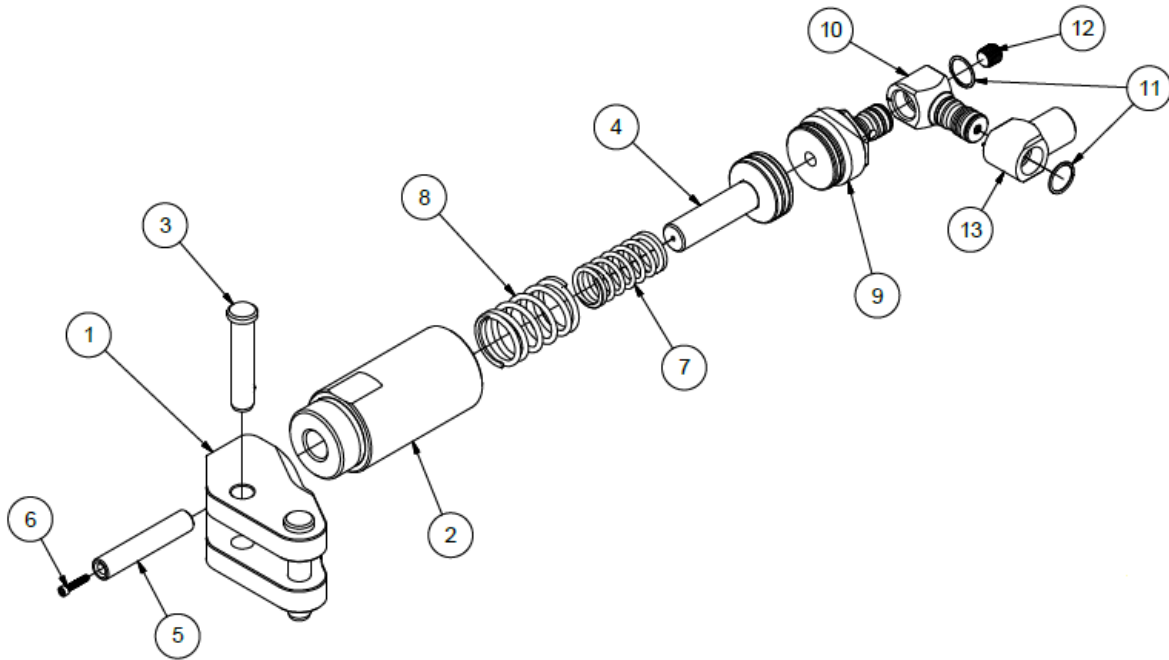

Parts List			
ITEM	QTY	PART NUMBER	DESCRIPTION
1	1	3061-2	BODY
2	1	3062-1	CYLINDER
3	2	3066-1	SHEAR PIN
4	1	3063-1	PISTON ASM
5	1	3054-4 (3054-2 IS ALSO INCLUDED WITH PURCHASE)	COMPRESSION PIN
6	2	91251A096	3-48 CAP SCREW
7	1	C0720-081-1500M	SPRING, RETURN
8	1	C0975-096-1500M	SPRING, RETURN
9	1	3065-2A	CYLINDER COVER ASM
10	1	3015-1A	DOUBLE AXIS SWIVEL ASM
11	2	WS-50	RETAINING RING
12	1	PP-1/16	1/16 NPT Plug
13	1	3014-1	90 DEG SWIVEL
14	1	7122A41 (NOT SHOWN)	5/64 HEX L-KEY

NXC-4 – EXPLODED PARTS VIEW

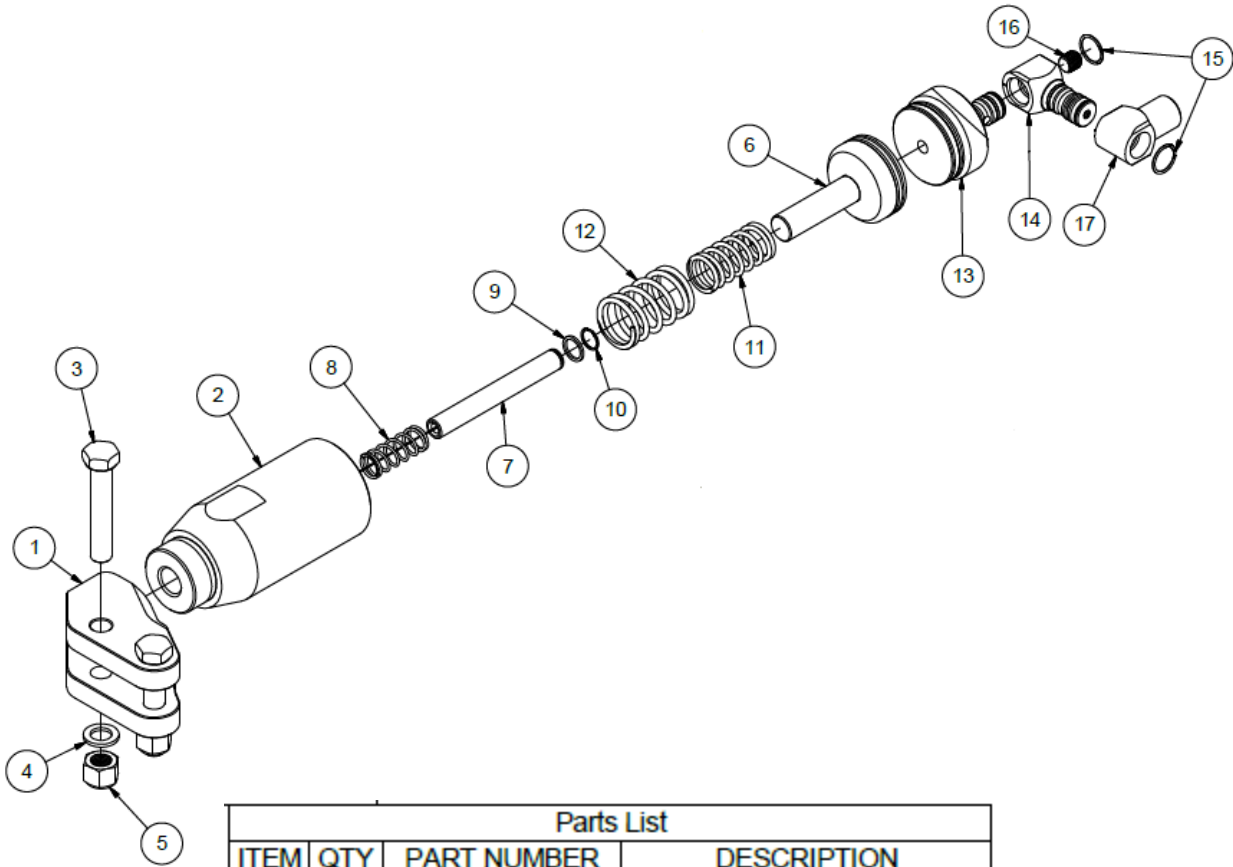

Parts List			
ITEM	QTY	PART NUMBER	DESCRIPTION
1	1	3061-2	BODY
2	1	3072-1	CYLINDER
3	2	3089-1	BOLT, SHEAR
4	2	AN960-616	WASHER
5	2	HDP-0125-1U	LOCKNUT
6	1	3073-1	PISTON ASM
7	1	3098-15	COMPRESSION PIN
8	1	C0480-045-1250M	SPRING, RETURN
9	1	3088-1	RING, RETAINER
10	1	WSM-37	RING, RETAINER
11	1	C0720-081-1500M	SPRING, RETURN
12	1	C0975-096-1500M	SPRING, RETURN
13	1	3075-2A	COVER, CYLINDER ASM
14	1	3015-1A	DOUBLE AXIS SWIVEL ASM
15	2	WS-50	RETAINING RING
16	1	PP-1/16	1/16 NPT Plug
17	1	3014-1	90 DEG SWIVEL

NXC-6 – EXPLODED PARTS VIEW

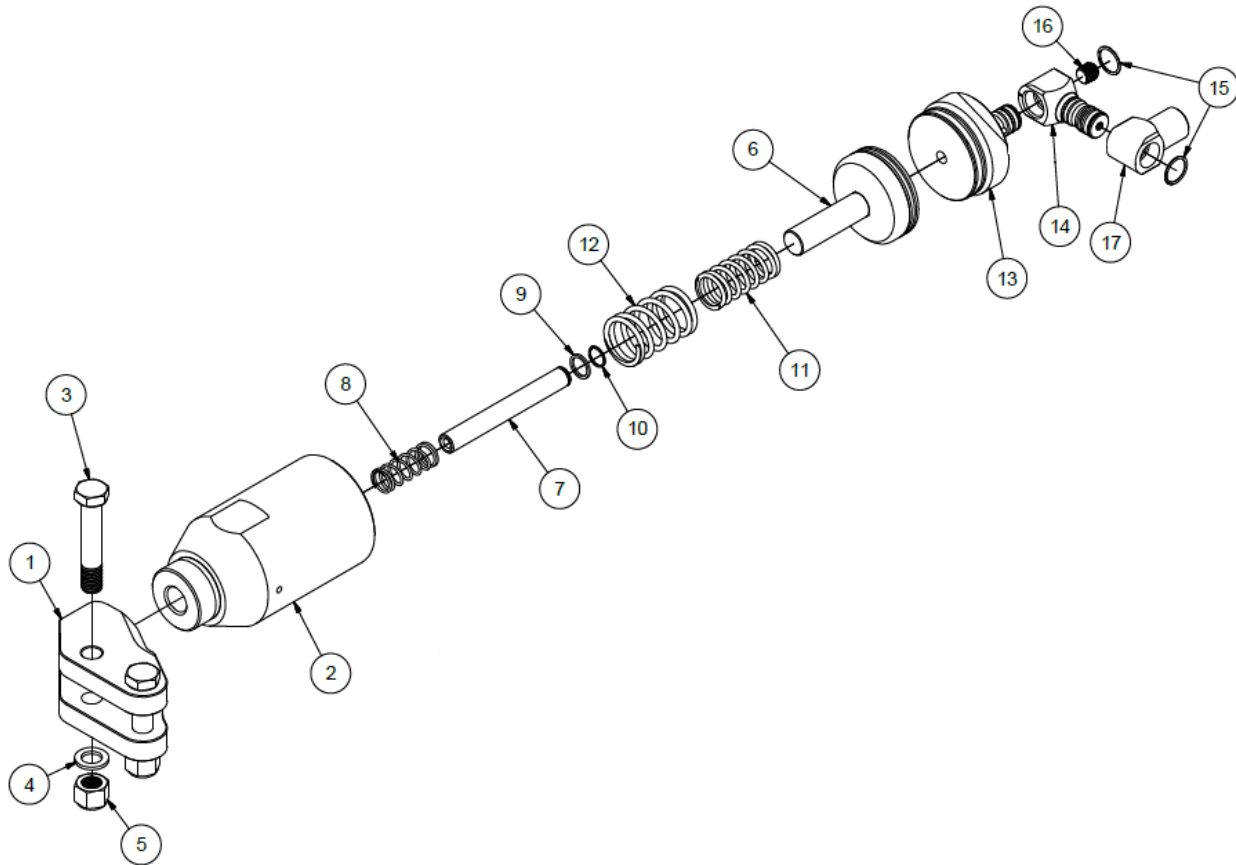

Parts List			
ITEM	QTY	PART NUMBER	DESCRIPTION
1	1	3061-3	BODY
2	1	3082-1	CYLINDER
3	2	3089-1	BOLT, SHEAR
4	2	AN960-616	WASHER
5	2	HDP-0125-1U	LOCKNUT
6	1	3083-1	PISTON ASM
7	1	3098-15	COMPRESSION PIN
8	1	C0480-045-1250M	SPRING, RETURN
9	1	3088-1	RING, RETAINER
10	1	WSM-37	RETAINING RING
11	1	C0720-081-1500M	SPRING, RETURN
12	1	C0975-096-1500M	SPRING, RETURN
13	1	3085-2A	COVER, CYLINDER ASM
14	1	3015-1A	DOUBLE AXIS SWIVEL ASM
15	2	WS-50	RING, RETAINER
16	1	PP-1/16	1/16 NPT PLUG
17	1	3014-1	90 DEG SWIVEL

NXC-9 – EXPLODED PARTS VIEW